



# VIKAS INDUSTRIES

A GOVT. OF INDIA RECOGNISED STAR EXPORT HOUSE

AN ISO 9001: 2015 CERTIFIED COMPANY

A UL LISTED COMPANY

 [www.vikasindustries.net](http://www.vikasindustries.net)



## INTRODUCTION

Established in 1993, Vikas Industries has emerged as a prominent player in different type of fittings including Strut, Kei Klamp, Fence Fittings, Scaffolding Accessories and Pipe Hangers market. With a strong foundation in technical expertise and a commitment to excellence, our company has earned a reputation for delivering high-quality products and services. Our dedicated team brings a wealth of knowledge and experience to every project led by Er. Vikas Garg. We are proud holders of ISO 9001:2015 and UL certifications, which reflect our commitment to stringent quality control and safety standards. These certifications validate our unwavering dedication to providing superior forged fittings that meet the highest industry requirements. At Vikas Industries, we prioritize customer satisfaction and foster long-lasting relationships based on trust and mutual success. Our state-of-the-art facilities enable us to maintain stringent quality control measures, ensuring the performance and durability of our forged fittings with our customer-centric approach, cutting-edge facilities and industry-recognized certifications, Vikas Industries is your trusted partner for high-quality Fittings.

## VISION

Grow markets with innovative solutions & products and create value for all stake holders by providing high quality engineered solutions to our customers

## MISSION

Our mission is to provide exceptional products that surpass industry standards, ensuring reliability, safety and optimal performance. We are committed to delivering superior solutions through rigorous quality control, technical expertise, and a customer-centric focus. Our goal is to meet the diverse needs of our valued customers, exceed their expectations, and achieve utmost customer satisfaction.

## PRODUCT RANGE

We are a renowned manufacturer of Strut Fittings, Tube Kei Fittings , Fence Fittings & Scaffolding Accessories specializing in a comprehensive range of high quality products. Our offerings include Strut Channels ,Channel Nuts, Chain Link Accessories, Barbs Arms, Pipe Kei Clamps, Waller plate, Forged Couplers, Pressed Couplers among others. With a steadfast commitment to excellence, we consistently deliver professional-grade solutions that meet stringent industry standards. Our dedication to following these standards guarantees the reliability, durability, and safety of our fittings, providing our customers with peace of mind and confidence in their applications

## QUALITY ASSURANCE

Vikas Industries upholds the highest standards of quality with certifications such as ISO 9001:2015 and UL Listing. Our ISO 9001:2015 certification reflects our comprehensive quality management system, ensuring excellence from research and development to design, manufacturing and inspection. As a UL Listed Company we guarantee safety and reliability of our products. Rigorous testing is conducted to ensure dimensional accuracy, load-bearing capacities, durability and overall performance. We take pride in providing top-notch products that meet the most stringent industry standards. Our dedicated team of experts combines technical expertise with advanced manufacturing techniques and engineering principles to design and produce superior forged fittings with our unwavering commitment to quality assurance, adherence to industry regulations and skilled craftsmanship, customers can trust in the technical superiority and performance of our products.



## Infrastructure



### State of The Art Equipments

With our state-of-the-art equipment, we unlock new possibilities for innovation, streamlining workflows, and achieving remarkable results. Our advanced machinery enables us to optimize productivity, minimize downtime, and maintain the highest standards of quality. We understand that utilizing the latest technology is essential in meeting the evolving needs of our clients and industries.

- Auto Feeding Line - 4
- Power Press - 60 ( from 5 to 1000 tonnes)
- CNC Machines - 50
- Knuckle joint for Cold Forgings - 7  
(from 250 tonnes to 1000 tonnes)
- Hot Forging Press / Hammers - 4)
- Circular Saw - 2
- Band Saw - 1
- SPM Drilling Machines - 14
- Traub Machines - 42
- Turning Machines - 16
- Spm Forming Machines - 26
- Centerless Grinders - 6
- Annealing Plant
- Galvanizing Plant
- Phosphating Plant (7 tank)

**Our Tool Room** is equipped with top-of-the-line machinery, ensuring world-class standards. Here is a list of the machines available in our facility

- Wirecut - 1
- VMC Machine - 1
- Turning Machines - 4
- Vertical Drill Machine (itcom)
- Vertical Milling Machine (pacmill)
- Automatic Surface Grinder (doall) - 2
- Surface Grinder - 3
- Drill Machines - 3
- Hand Grinders - 3



-We also have an internal welding division that encompasses a wide range of welding methods, including mig welding, projection welding, spot welding, and tig welding.

- with the aid of stripping machines and heat shrink machines, we maintain the highest standards of quality and precision in our packing procedures.

- we have stamping machines and laser marking machines specifically designed to imprint the unique part numbers on each component.

**Testing Facilities**



**High Resolution Profile Projector**  
High resolution profile projector: Enables precise measurement and inspection of complex profiles, reducing errors and improving quality control.



**Hardness Tester**  
Measures material hardness, ensuring suitability for specific applications and maintaining quality standards.



**Height Gauge with Surface Table**  
Provides accurate vertical measurements, ensuring proper alignment and assembly in manufacturing processes.



**Micrometer And Digital Vernier Caliper**  
Offers precise measurements of small distances and diameters, ensuring tight tolerances and consistent product quality. A Digital Vernier Caliper Provides measurements of length, depth, and thickness with a digital display.



**Tensile Tester**  
Tensile Tester: Evaluates material strength and performance under tension, validating design specifications and ensuring product reliability.



**Gauges**  
NPT Thread and plug gauges are precision tools used to measure the size and accuracy of screw threads and holes.

**Certifications**



**STAR EXPORT HOUSE**



**ISO 9001:2015**

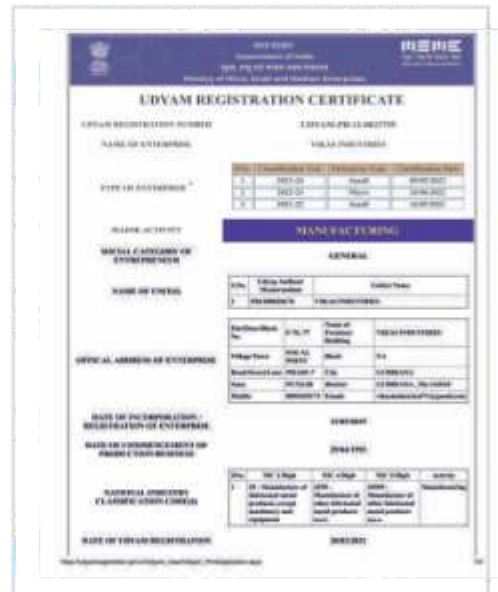

**UDYAM REGISTRATION**

**Certificate of Compliance**

**CERTIFICATE OF COMPLIANCE**

**Certificate Number:** EK28827  
**Report Reference:** EK28827-20230505  
**Date:** 2023-May-06

**Issued to:** Vikas Industries  
 F-76-77, Phase - VI  
 Ludhiana Punjab, 141019 IN

**This is to certify that representative samples of** HANGERS, PIPE  
 See Addendum Page for Product Designation(s).

Have been evaluated by UL in accordance with the Standard(s) indicated on this Certificate.

**Standard(s) for Safety:** ANSICAN/UL 203:2020 - Standard for Pipe Hanger Equipment for Fire Protection Service

**Additional Information:** See the UL Online Certifications Directory at <https://ul.com/certdir> for additional information

This Certificate of Compliance indicates that representative samples of the product described in the certification report have met the requirements for UL certification. It does not provide authorization to apply the UL Mark. Only the Authorization Page that references the Follow-Up Services Procedure for ongoing surveillance provides authorization to apply the UL Mark.

Only those products bearing the UL Mark should be considered as being UL Certified and covered under UL's Follow-Up Services.

Look for the UL Certification Mark on the product.



**CERTIFICATE OF COMPLIANCE**

**Certificate Number:** EK28827  
**Report Reference:** EK28827-20230505  
**Date:** 2023-May-06

This is to certify that representative samples of the product as specified on this certificate were tested according to the current UL requirements.

**Pipe Hangers**

**Models:**  
 VICH-01, VICH-02, VICH-03, VICH-04, VICH-05, VICH-06, VICH-07, VICH-08, VICH-09, VICH-10, VICH-11, VICH-01, VICH-02, VICH-03, VICH-04, VICH-05, VICH-06, VICH-07, VICH-08, VICH-09, VICH-10, VICH-11, VRNC-01, VRNC-02, VRNC-03, VRNC-04, VRNC-05, VRNC-06, VRNC-07, VRNC-08, VRNC-09, VRNC-10, VRNC-11, VRNC-12, VRNC-13



**CERTIFICATE OF COMPLIANCE**

**This certificate of compliance certifies the following:**

REPORT NUMBER	ISSUED DATE	CERTIFICATE NUMBER	ULI CODE
Report Reference: EK28827-20230505	2023-05-06	EK28827	VIKAS
DATE OF ISSUE	DATE OF EXPIRY	DATE OF EXPIRY	DATE OF EXPIRY
2023-05-06	2023-05-06	2023-05-06	2023-05-06
DATE OF EXPIRY	DATE OF EXPIRY	DATE OF EXPIRY	DATE OF EXPIRY
2023-05-06	2023-05-06	2023-05-06	2023-05-06

**Manufacturer details**

NAME OF FACTORY / MANUFACTURER	ADDRESS	NAME OF THE BRAND	VIKAS, VIKAS-1, VIKAS-2, VIKAS-3, VIKAS-4, VIKAS-5, VIKAS-6, VIKAS-7, VIKAS-8, VIKAS-9, VIKAS-10, VIKAS-11, VIKAS-12, VIKAS-13, VIKAS-14, VIKAS-15, VIKAS-16, VIKAS-17, VIKAS-18, VIKAS-19, VIKAS-20, VIKAS-21, VIKAS-22, VIKAS-23, VIKAS-24, VIKAS-25, VIKAS-26, VIKAS-27, VIKAS-28, VIKAS-29, VIKAS-30, VIKAS-31, VIKAS-32, VIKAS-33, VIKAS-34, VIKAS-35, VIKAS-36, VIKAS-37, VIKAS-38, VIKAS-39, VIKAS-40, VIKAS-41, VIKAS-42, VIKAS-43, VIKAS-44, VIKAS-45, VIKAS-46, VIKAS-47, VIKAS-48, VIKAS-49, VIKAS-50, VIKAS-51, VIKAS-52, VIKAS-53, VIKAS-54, VIKAS-55, VIKAS-56, VIKAS-57, VIKAS-58, VIKAS-59, VIKAS-60, VIKAS-61, VIKAS-62, VIKAS-63, VIKAS-64, VIKAS-65, VIKAS-66, VIKAS-67, VIKAS-68, VIKAS-69, VIKAS-70, VIKAS-71, VIKAS-72, VIKAS-73, VIKAS-74, VIKAS-75, VIKAS-76, VIKAS-77, VIKAS-78, VIKAS-79, VIKAS-80, VIKAS-81, VIKAS-82, VIKAS-83, VIKAS-84, VIKAS-85, VIKAS-86, VIKAS-87, VIKAS-88, VIKAS-89, VIKAS-90, VIKAS-91, VIKAS-92, VIKAS-93, VIKAS-94, VIKAS-95, VIKAS-96, VIKAS-97, VIKAS-98, VIKAS-99, VIKAS-100
VIKAS INDUSTRIES	F-76-77, Phase - VI, Ludhiana Punjab, 141019 IN	VIKAS	VIKAS, VIKAS-1, VIKAS-2, VIKAS-3, VIKAS-4, VIKAS-5, VIKAS-6, VIKAS-7, VIKAS-8, VIKAS-9, VIKAS-10, VIKAS-11, VIKAS-12, VIKAS-13, VIKAS-14, VIKAS-15, VIKAS-16, VIKAS-17, VIKAS-18, VIKAS-19, VIKAS-20, VIKAS-21, VIKAS-22, VIKAS-23, VIKAS-24, VIKAS-25, VIKAS-26, VIKAS-27, VIKAS-28, VIKAS-29, VIKAS-30, VIKAS-31, VIKAS-32, VIKAS-33, VIKAS-34, VIKAS-35, VIKAS-36, VIKAS-37, VIKAS-38, VIKAS-39, VIKAS-40, VIKAS-41, VIKAS-42, VIKAS-43, VIKAS-44, VIKAS-45, VIKAS-46, VIKAS-47, VIKAS-48, VIKAS-49, VIKAS-50, VIKAS-51, VIKAS-52, VIKAS-53, VIKAS-54, VIKAS-55, VIKAS-56, VIKAS-57, VIKAS-58, VIKAS-59, VIKAS-60, VIKAS-61, VIKAS-62, VIKAS-63, VIKAS-64, VIKAS-65, VIKAS-66, VIKAS-67, VIKAS-68, VIKAS-69, VIKAS-70, VIKAS-71, VIKAS-72, VIKAS-73, VIKAS-74, VIKAS-75, VIKAS-76, VIKAS-77, VIKAS-78, VIKAS-79, VIKAS-80, VIKAS-81, VIKAS-82, VIKAS-83, VIKAS-84, VIKAS-85, VIKAS-86, VIKAS-87, VIKAS-88, VIKAS-89, VIKAS-90, VIKAS-91, VIKAS-92, VIKAS-93, VIKAS-94, VIKAS-95, VIKAS-96, VIKAS-97, VIKAS-98, VIKAS-99, VIKAS-100
FACTORY CODES / BRAND	MARK / NO.	MARK / NO.	MARK / NO.
VIKAS	VIKAS	VIKAS	VIKAS
MARKS	END OF THE PRODUCT	END OF THE PRODUCT	END OF THE PRODUCT
VIKAS	VIKAS	VIKAS	VIKAS



**CERTIFICATE OF COMPLIANCE**

**This certificate of compliance certifies the following:**

REPORT NUMBER	ISSUED DATE	CERTIFICATE NUMBER	ULI CODE
Report Reference: EK28827-20230505	2023-05-06	EK28827	VIKAS
DATE OF ISSUE	DATE OF EXPIRY	DATE OF EXPIRY	DATE OF EXPIRY
2023-05-06	2023-05-06	2023-05-06	2023-05-06
DATE OF EXPIRY	DATE OF EXPIRY	DATE OF EXPIRY	DATE OF EXPIRY
2023-05-06	2023-05-06	2023-05-06	2023-05-06

**Manufacturer details**

NAME OF FACTORY / MANUFACTURER	ADDRESS	NAME OF THE BRAND	VIKAS, VIKAS-1, VIKAS-2, VIKAS-3, VIKAS-4, VIKAS-5, VIKAS-6, VIKAS-7, VIKAS-8, VIKAS-9, VIKAS-10, VIKAS-11, VIKAS-12, VIKAS-13, VIKAS-14, VIKAS-15, VIKAS-16, VIKAS-17, VIKAS-18, VIKAS-19, VIKAS-20, VIKAS-21, VIKAS-22, VIKAS-23, VIKAS-24, VIKAS-25, VIKAS-26, VIKAS-27, VIKAS-28, VIKAS-29, VIKAS-30, VIKAS-31, VIKAS-32, VIKAS-33, VIKAS-34, VIKAS-35, VIKAS-36, VIKAS-37, VIKAS-38, VIKAS-39, VIKAS-40, VIKAS-41, VIKAS-42, VIKAS-43, VIKAS-44, VIKAS-45, VIKAS-46, VIKAS-47, VIKAS-48, VIKAS-49, VIKAS-50, VIKAS-51, VIKAS-52, VIKAS-53, VIKAS-54, VIKAS-55, VIKAS-56, VIKAS-57, VIKAS-58, VIKAS-59, VIKAS-60, VIKAS-61, VIKAS-62, VIKAS-63, VIKAS-64, VIKAS-65, VIKAS-66, VIKAS-67, VIKAS-68, VIKAS-69, VIKAS-70, VIKAS-71, VIKAS-72, VIKAS-73, VIKAS-74, VIKAS-75, VIKAS-76, VIKAS-77, VIKAS-78, VIKAS-79, VIKAS-80, VIKAS-81, VIKAS-82, VIKAS-83, VIKAS-84, VIKAS-85, VIKAS-86, VIKAS-87, VIKAS-88, VIKAS-89, VIKAS-90, VIKAS-91, VIKAS-92, VIKAS-93, VIKAS-94, VIKAS-95, VIKAS-96, VIKAS-97, VIKAS-98, VIKAS-99, VIKAS-100
VIKAS INDUSTRIES	F-76-77, Phase - VI, Ludhiana Punjab, 141019 IN	VIKAS	VIKAS, VIKAS-1, VIKAS-2, VIKAS-3, VIKAS-4, VIKAS-5, VIKAS-6, VIKAS-7, VIKAS-8, VIKAS-9, VIKAS-10, VIKAS-11, VIKAS-12, VIKAS-13, VIKAS-14, VIKAS-15, VIKAS-16, VIKAS-17, VIKAS-18, VIKAS-19, VIKAS-20, VIKAS-21, VIKAS-22, VIKAS-23, VIKAS-24, VIKAS-25, VIKAS-26, VIKAS-27, VIKAS-28, VIKAS-29, VIKAS-30, VIKAS-31, VIKAS-32, VIKAS-33, VIKAS-34, VIKAS-35, VIKAS-36, VIKAS-37, VIKAS-38, VIKAS-39, VIKAS-40, VIKAS-41, VIKAS-42, VIKAS-43, VIKAS-44, VIKAS-45, VIKAS-46, VIKAS-47, VIKAS-48, VIKAS-49, VIKAS-50, VIKAS-51, VIKAS-52, VIKAS-53, VIKAS-54, VIKAS-55, VIKAS-56, VIKAS-57, VIKAS-58, VIKAS-59, VIKAS-60, VIKAS-61, VIKAS-62, VIKAS-63, VIKAS-64, VIKAS-65, VIKAS-66, VIKAS-67, VIKAS-68, VIKAS-69, VIKAS-70, VIKAS-71, VIKAS-72, VIKAS-73, VIKAS-74, VIKAS-75, VIKAS-76, VIKAS-77, VIKAS-78, VIKAS-79, VIKAS-80, VIKAS-81, VIKAS-82, VIKAS-83, VIKAS-84, VIKAS-85, VIKAS-86, VIKAS-87, VIKAS-88, VIKAS-89, VIKAS-90, VIKAS-91, VIKAS-92, VIKAS-93, VIKAS-94, VIKAS-95, VIKAS-96, VIKAS-97, VIKAS-98, VIKAS-99, VIKAS-100
FACTORY CODES / BRAND	MARK / NO.	MARK / NO.	MARK / NO.
VIKAS	VIKAS	VIKAS	VIKAS
MARKS	END OF THE PRODUCT	END OF THE PRODUCT	END OF THE PRODUCT
VIKAS	VIKAS	VIKAS	VIKAS



**CERTIFICATE OF COMPLIANCE**

**This certificate of compliance certifies the following:**

REPORT NUMBER	ISSUED DATE	CERTIFICATE NUMBER	ULI CODE
Report Reference: EK28827-20230505	2023-05-06	EK28827	VIKAS
DATE OF ISSUE	DATE OF EXPIRY	DATE OF EXPIRY	DATE OF EXPIRY
2023-05-06	2023-05-06	2023-05-06	2023-05-06
DATE OF EXPIRY	DATE OF EXPIRY	DATE OF EXPIRY	DATE OF EXPIRY
2023-05-06	2023-05-06	2023-05-06	2023-05-06

**Manufacturer details**

NAME OF FACTORY / MANUFACTURER	ADDRESS	NAME OF THE BRAND	VIKAS, VIKAS-1, VIKAS-2, VIKAS-3, VIKAS-4, VIKAS-5, VIKAS-6, VIKAS-7, VIKAS-8, VIKAS-9, VIKAS-10, VIKAS-11, VIKAS-12, VIKAS-13, VIKAS-14, VIKAS-15, VIKAS-16, VIKAS-17, VIKAS-18, VIKAS-19, VIKAS-20, VIKAS-21, VIKAS-22, VIKAS-23, VIKAS-24, VIKAS-25, VIKAS-26, VIKAS-27, VIKAS-28, VIKAS-29, VIKAS-30, VIKAS-31, VIKAS-32, VIKAS-33, VIKAS-34, VIKAS-35, VIKAS-36, VIKAS-37, VIKAS-38, VIKAS-39, VIKAS-40, VIKAS-41, VIKAS-42, VIKAS-43, VIKAS-44, VIKAS-45, VIKAS-46, VIKAS-47, VIKAS-48, VIKAS-49, VIKAS-50, VIKAS-51, VIKAS-52, VIKAS-53, VIKAS-54, VIKAS-55, VIKAS-56, VIKAS-57, VIKAS-58, VIKAS-59, VIKAS-60, VIKAS-61, VIKAS-62, VIKAS-63, VIKAS-64, VIKAS-65, VIKAS-66, VIKAS-67, VIKAS-68, VIKAS-69, VIKAS-70, VIKAS-71, VIKAS-72, VIKAS-73, VIKAS-74, VIKAS-75, VIKAS-76, VIKAS-77, VIKAS-78, VIKAS-79, VIKAS-80, VIKAS-81, VIKAS-82, VIKAS-83, VIKAS-84, VIKAS-85, VIKAS-86, VIKAS-87, VIKAS-88, VIKAS-89, VIKAS-90, VIKAS-91, VIKAS-92, VIKAS-93, VIKAS-94, VIKAS-95, VIKAS-96, VIKAS-97, VIKAS-98, VIKAS-99, VIKAS-100
VIKAS INDUSTRIES	F-76-77, Phase - VI, Ludhiana Punjab, 141019 IN	VIKAS	VIKAS, VIKAS-1, VIKAS-2, VIKAS-3, VIKAS-4, VIKAS-5, VIKAS-6, VIKAS-7, VIKAS-8, VIKAS-9, VIKAS-10, VIKAS-11, VIKAS-12, VIKAS-13, VIKAS-14, VIKAS-15, VIKAS-16, VIKAS-17, VIKAS-18, VIKAS-19, VIKAS-20, VIKAS-21, VIKAS-22, VIKAS-23, VIKAS-24, VIKAS-25, VIKAS-26, VIKAS-27, VIKAS-28, VIKAS-29, VIKAS-30, VIKAS-31, VIKAS-32, VIKAS-33, VIKAS-34, VIKAS-35, VIKAS-36, VIKAS-37, VIKAS-38, VIKAS-39, VIKAS-40, VIKAS-41, VIKAS-42, VIKAS-43, VIKAS-44, VIKAS-45, VIKAS-46, VIKAS-47, VIKAS-48, VIKAS-49, VIKAS-50, VIKAS-51, VIKAS-52, VIKAS-53, VIKAS-54, VIKAS-55, VIKAS-56, VIKAS-57, VIKAS-58, VIKAS-59, VIKAS-60, VIKAS-61, VIKAS-62, VIKAS-63, VIKAS-64, VIKAS-65, VIKAS-66, VIKAS-67, VIKAS-68, VIKAS-69, VIKAS-70, VIKAS-71, VIKAS-72, VIKAS-73, VIKAS-74, VIKAS-75, VIKAS-76, VIKAS-77, VIKAS-78, VIKAS-79, VIKAS-80, VIKAS-81, VIKAS-82, VIKAS-83, VIKAS-84, VIKAS-85, VIKAS-86, VIKAS-87, VIKAS-88, VIKAS-89, VIKAS-90, VIKAS-91, VIKAS-92, VIKAS-93, VIKAS-94, VIKAS-95, VIKAS-96, VIKAS-97, VIKAS-98, VIKAS-99, VIKAS-100
FACTORY CODES / BRAND	MARK / NO.	MARK / NO.	MARK / NO.
VIKAS	VIKAS	VIKAS	VIKAS
MARKS	END OF THE PRODUCT	END OF THE PRODUCT	END OF THE PRODUCT
VIKAS	VIKAS	VIKAS	VIKAS



**Index**

**STRUT CHANNEL & ACCESSORIES..... Page No.6 to 11**



**HANGERS & PIPE CLAMPS..... Page No.12**

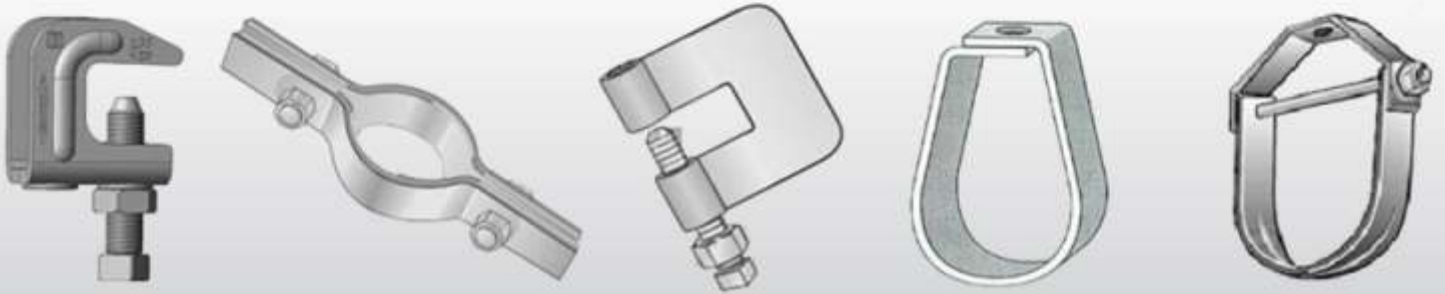

**CHAIN LINK FENCE ACCESSORIES..... Page No.13 to 16**



**KEI KLAMP PIPE FITTINGS..... Page No.17 to 22**



**CC21  
SHALLOW CHANNEL PLAIN**

Standard Finish : Pre Galvanised | Hot Dipped Galvanised

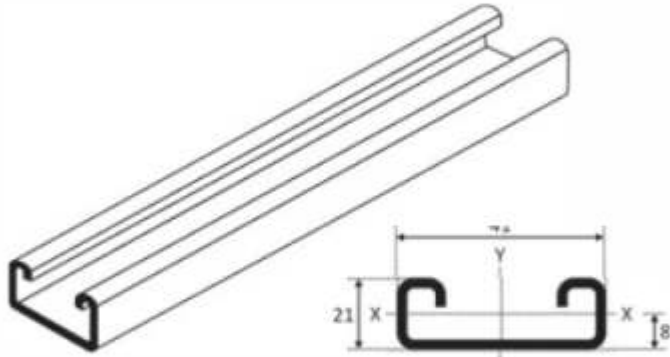

**CC2121  
SHALLOW CHANNEL DOUBLE**

Standard Finish : Pre Galvanised | Hot Dipped Galvanised

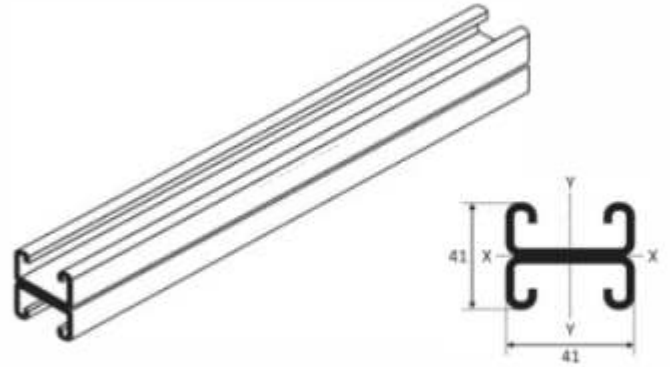

**CC41  
DEEP CHANNEL PLAIN**

Standard Finish : Pre Galvanised | Hot Dipped Galvanised

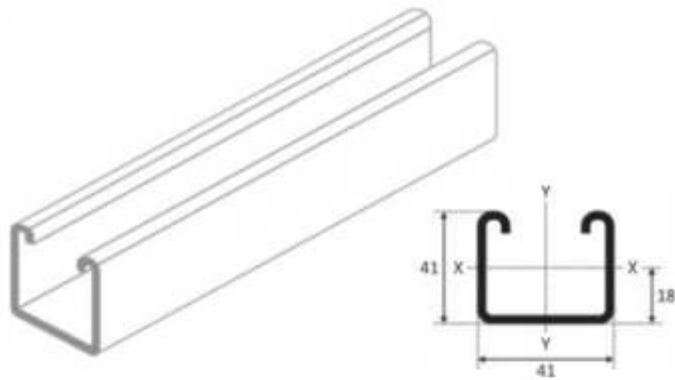

**CC4141  
DEEP CHANNEL DOUBLE**

Standard Finish : Pre Galvanised | Hot Dipped Galvanised

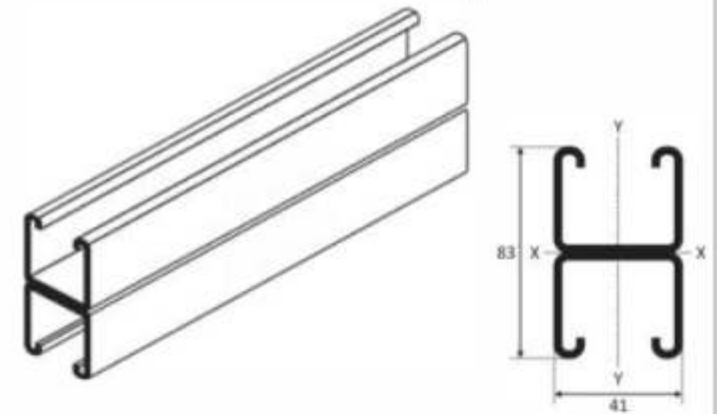

**CC21S  
SHALLOW CHANNEL SLOTTED**

Standard Finish : Pre Galvanised | Hot Dipped Galvanised

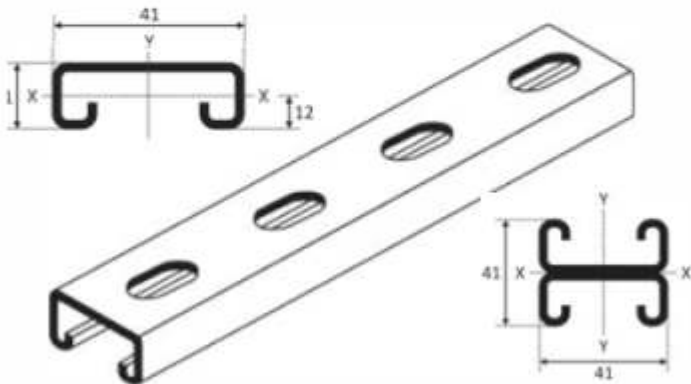

**CC41S  
DEEP CHANNEL SLOTTED**

Standard Finish : Pre Galvanised | Hot Dipped Galvanised

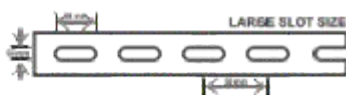
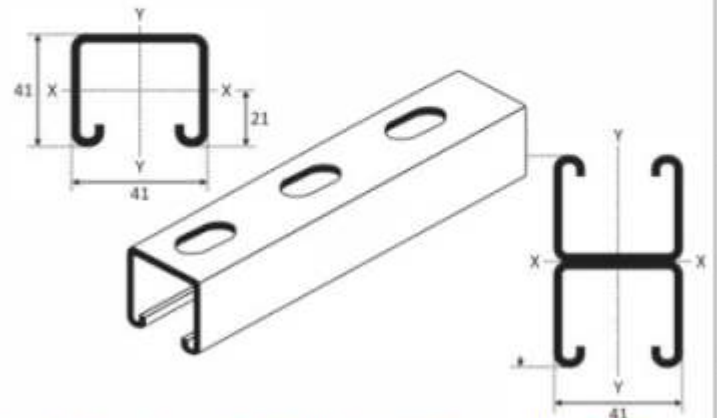

# CHANNEL NUTS

## WITHOUT SPRING



Size	Thd	Thk
1/4" (6mm)	20	1/4" (6mm)
3/8" (10mm)	16	3/8" (10mm)
1/2" (12mm)	13	3/8" (10mm)
1/2" (12mm)	13	1/2" (12mm)
5/8" (16mm)	11	7/16" (11mm)
3/4" (18mm)	10	7/16" (11mm)
5/8" (16mm)	11	3/8" (10mm)
3/4" (18mm)	10	3/8" (10mm)
5/16" (8mm)	18	3/8" (10mm)
7/8" (22mm)	9	7/16" (11mm)

## SHORT SPRING



Size	Thd	Thk
1/4" (6mm)	20	1/4" (6mm)
3/8" (10mm)	16	3/8" (10mm)
1/2" (12mm)	13	3/8" (10mm)
5/8" (16mm)	11	3/8" (10mm)
3/4" (18mm)	10	3/8" (10mm)
5/16" (8mm)	18	3/8" (10mm)

## LONG SPRING



Size	Thd	Thk
1/4" (6mm)	20	1/4" (6mm)
3/8" (10mm)	16	3/8" (10mm)
1/2" (12mm)	13	3/8" (10mm)
1/2" (12mm)	13	1/2" (12mm)
5/8" (16mm)	11	7/16" (11mm)
3/4" (18mm)	10	7/16" (11mm)
5/16" (8mm)	18	3/8" (10mm)

## TOP SPRING NUT



Size	Thd	Thk
1/4" (6mm)	20	1/4" (6mm)
3/8" (10mm)	16	3/8" (10mm)
1/2" (12mm)	13	3/8" (10mm)
5/16" (8mm)	18	3/8" (10mm)

## WEDGE NUT



Size	Thd	Thk
1/4" (6mm)	20	1/4" (6mm)
3/8" (10mm)	16	3/8" (10mm)
1/2" (12mm)	13	3/8" (10mm)
5/16" (8mm)	18	3/8" (10mm)

Standard Finish : Pre Galvanised | Hot Dipped Galvanised



# CHANNEL FITTINGS - FLAT PLATES

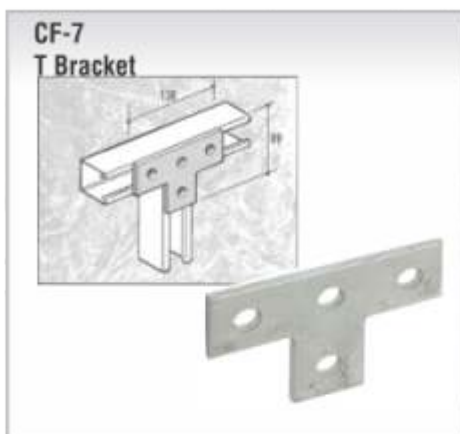
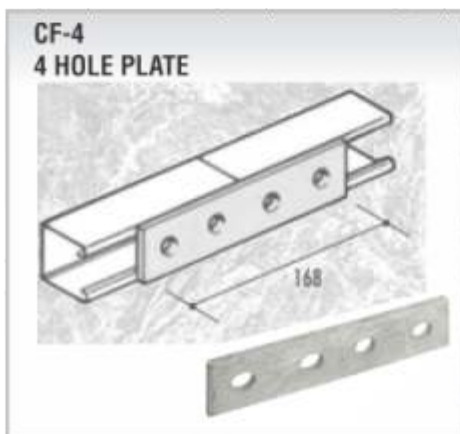
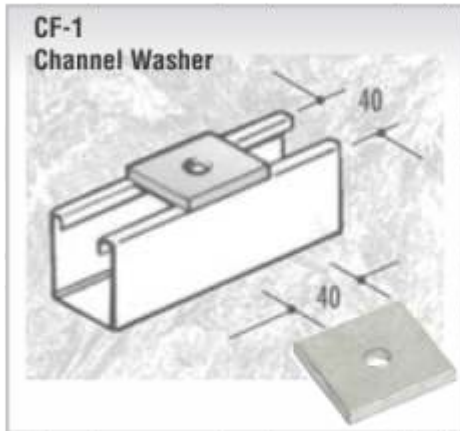

# CHANNEL FITTINGS - ANGLE PLATES

**CF-14**  
90 DEGREE BRACKET

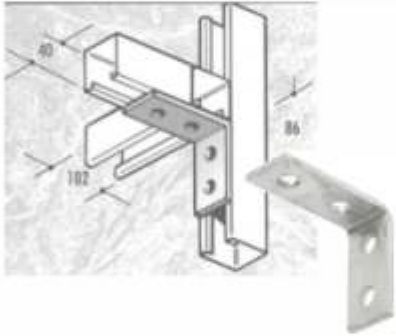

**CF-15**  
SHELF BRACKET

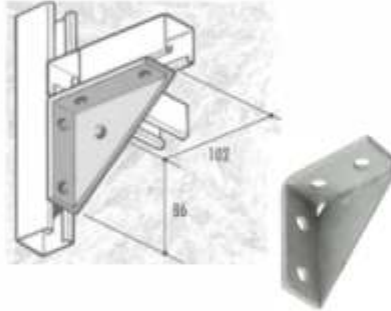

**CF-17**  
90 DEGREE DELTA BRACKET

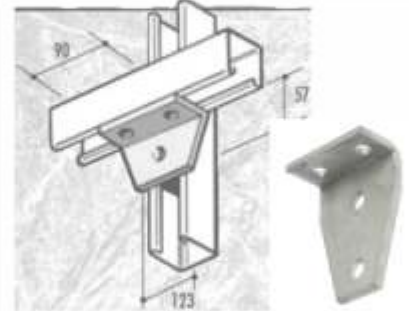

**CF-18**  
90 DEGREE DELTA BRACKET

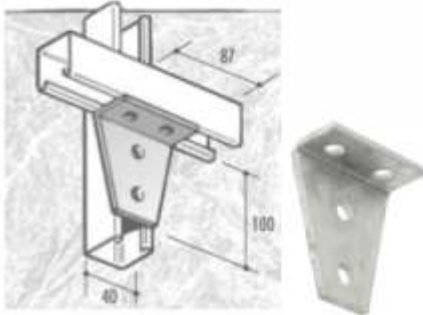

**CF-19**  
90 DEGREE ANGLED "T" BRACKET

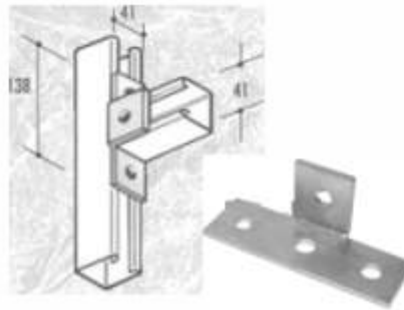

**CF-20**  
90 DEGREE ANGLED LEFT "T" BRACKET

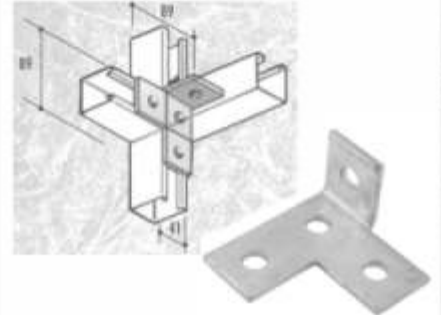

**CF-21**  
90 DEGREE ANGLED RIGHT "T" BRACKET

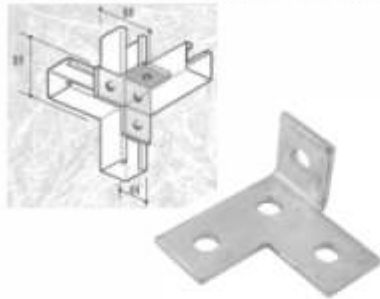

**CF-22**  
"Z" BRACKET TOP HAT

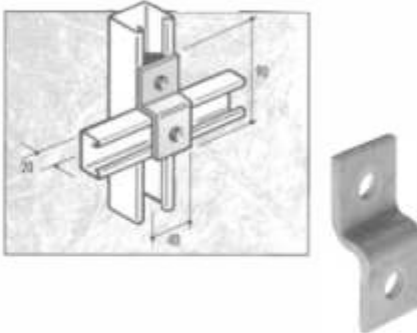

**CF-23**  
SINGLE "Z" BRACKET

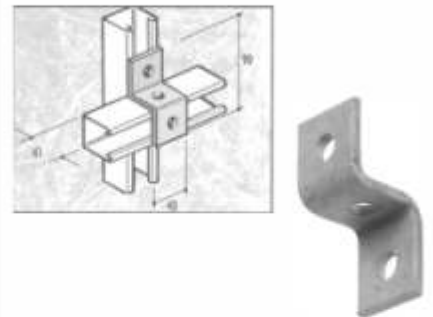

**CF-24**  
SINGLE "Z" BRACKET

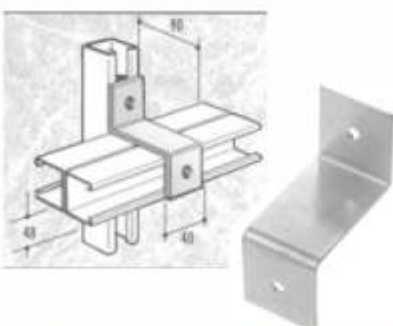

**CF-25**  
HALF CHANNEL TOP HAT

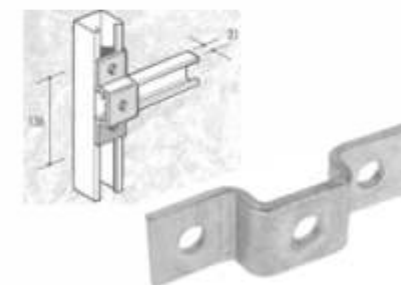

**CF-26**  
TOP HAT

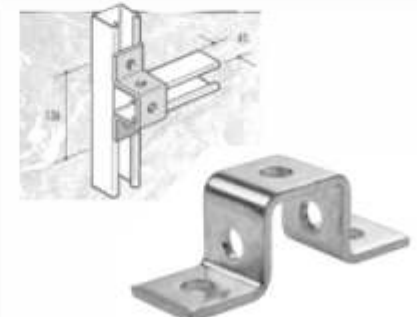

# CHANNEL FITTINGS - JOINERS & BASE PLATES

**CF-27  
TOP HAT**

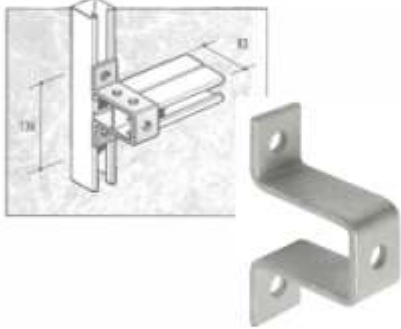

**CF-28  
DOUBLE WIDTH TOP HAT**



**CF-29/45  
ANGLED BRACKET**

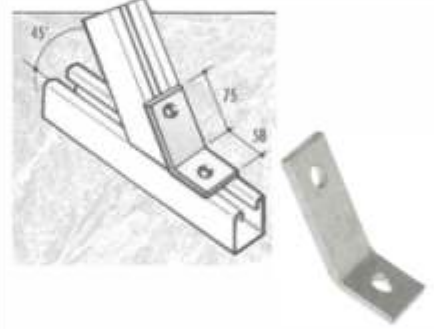

**CF-30/45  
ANGLED BRACKET**

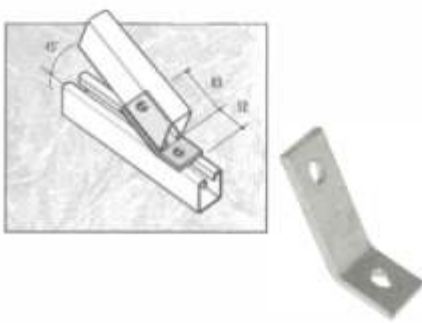

**CF-31  
ACUTE ANGLED "T" BRACKET**

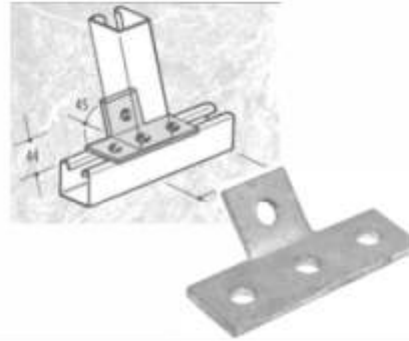

**CF-31/45  
ACUTE ANGLED "T" BRACKET**

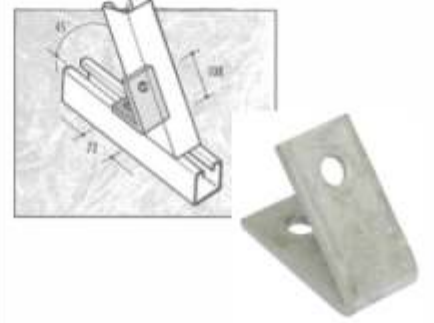

**CF-33/21  
EXTERNAL CONNECTOR**



**CF-33/41  
EXTERNAL CONNECTOR**

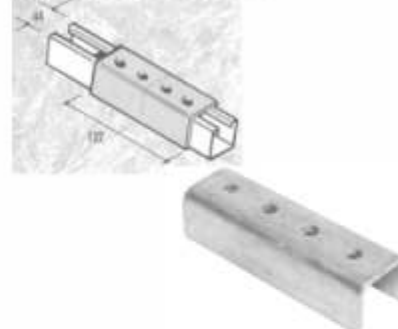

**CF-36/21  
INTERNAL CONNECTOR**

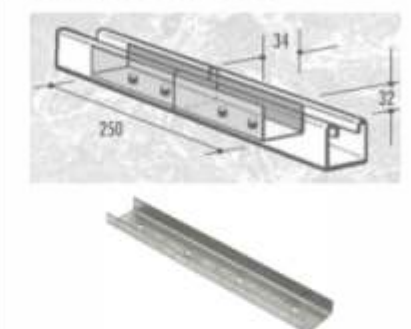

**CF-36/41  
INTERNAL CONNECTOR**

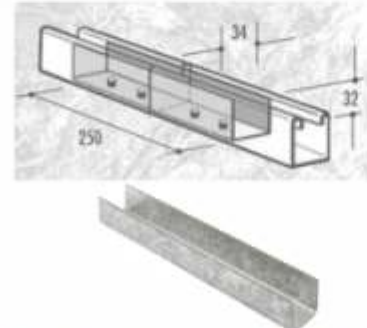

**CF-37  
BASE PLATE FOR DOUBLE CHANNEL**

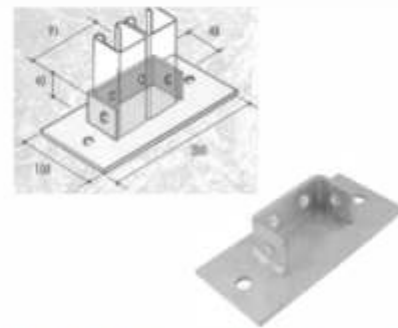

**CF-38  
BASE PLATE DOUBLE FIX**

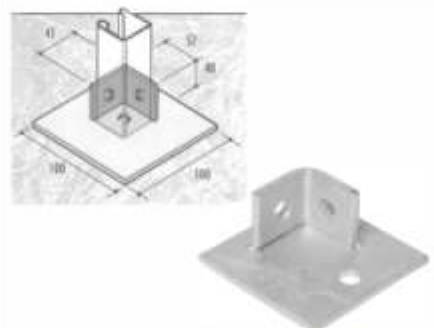

# CHANNEL FITTINGS - JOINERS & BASE PLATES

**CF-39  
BASE PLATE SINGLE FIX**

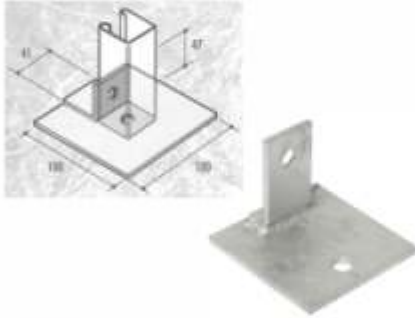

**CF-40/41  
SINGLE DELTA PLATE**

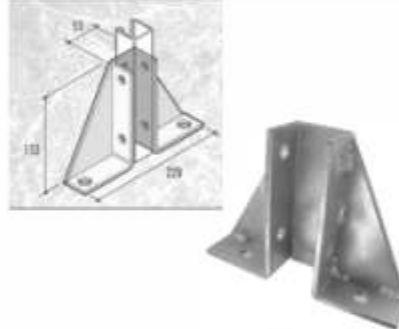

**CF-40/82  
DOUBLE DELTA BRACKET**

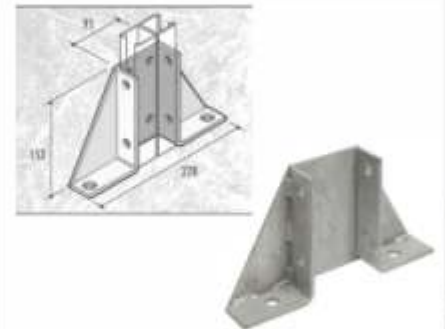

**CF-42  
CHANNEL 'T' BRACKET**



**CF-43  
BEAM CLAMP TAPPED M10**



**CF-44  
BEAM CLAMP TAPPED M10**



**CF-45/21  
BEAM CLAMP**

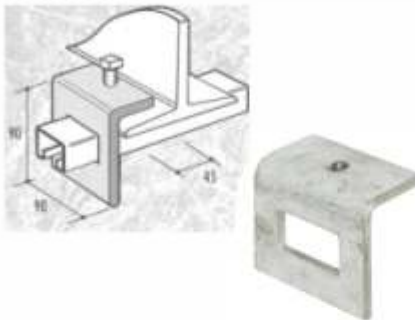

**CF-45/41  
BEAM CLAMP**

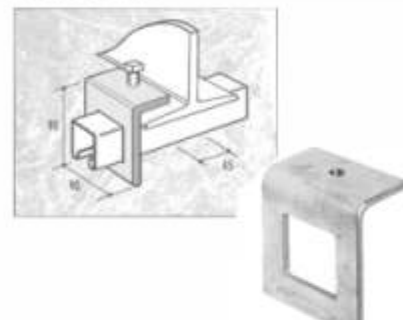

**CF-46-UL  
BEAM CLAMP 'U'BOLT**

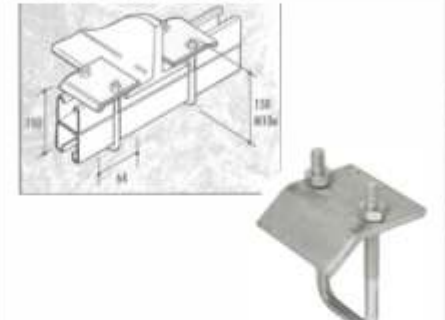

**CF-46 UM  
BEAM CLAMP 'U'BOLT**

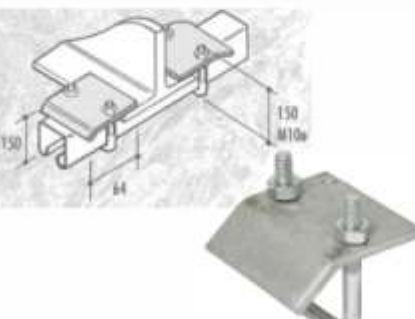

**CF-47  
'Z' BEAM CLAMP TAPPED M 10**

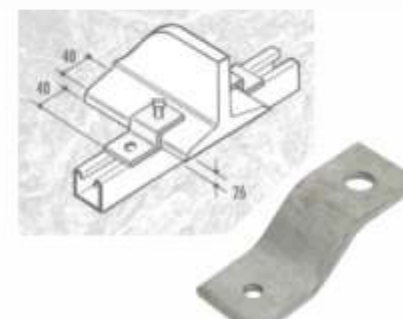

**CF-48  
BEAM CLAMP**

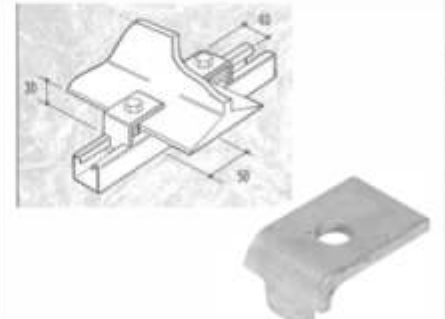

# RANGE OF PREMIUM HANGERS, CLAMPS & ACCESSORIES

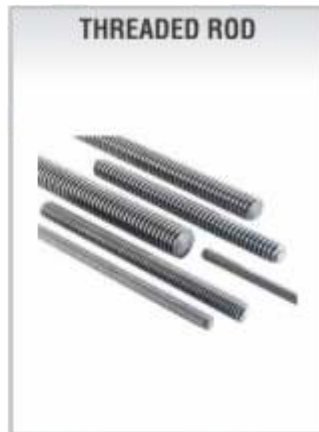
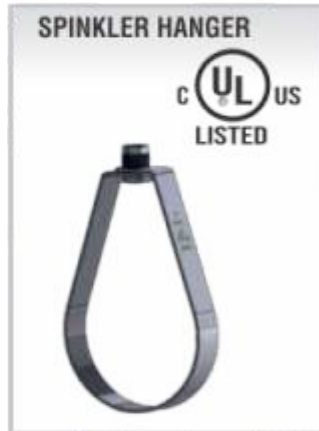

# CHAIN LINK FENCE ACCESSORIES

## VIFF - 01 : BARB ARM SINGLE

Standard Finish : Pre Galvanised | Hot Dipped Galvanised

- **Material:** Pressed Mild Steel.

OD POST	TOP RAIL
1-5/8"	1-5/8"
2"	1-5/8"
2-1/2"	1-5/8"



## VIFF - 02 : BARB ARM DOUBLE

Standard Finish : Pre Galvanised | Hot Dipped Galvanised

- **Material:** Pressed Mild Steel.

OD POST	TOP RAIL
1-5/8"	1-5/8"
2"	1-5/8"
2-1/2"	1-5/8"



## VIFF - 03 : TENSION BAND

Standard Finish : Pre Galvanised | Hot Dipped Galvanised

- **Material:** Pressed Mild Steel.
- **Thickness:** 10-16 gauge.
- **Minimum width:** 3/4".
- **Size:** 1-3/8", 1-5/8", 2", 2-1/2", 3", 3-1/2", 4", 6-5/8".



## VIFF - 04 : BRACE BAND

Standard Finish : Pre Galvanised | Hot Dipped Galvanised

- **Material:** Pressed Mild Steel.
- **Thickness:** 10-16 gauge.
- **Minimum width:** 3/4".
- **Size:** 1-3/8", 1-5/8", 2", 2-1/2", 3", 4", 6-5/8".



## VIFF - 05 : RAIL END STRAIGHT

Standard Finish : Zinc Coating / Hot Dipped Galvanised

- **Material:** Pressed Mild Steel.
- **Diameter:** 1-3/8", 1-5/8", 2", 2-1/2", 3"



## VIFF - 06 : RAIL END STRAIGHT

Standard Finish : Zinc Coating / Hot Dipped Galvanised

- **Material:** Pressed Mild Steel.
- **Diameter:** 1-3/8", 1-5/8", 2", 2-1/2", 3"



## VIFF - 07 : POST CAP PLAIN

Standard Finish : Pre Galvanised | Hot Dipped Galvanised

- **Material:** Pressed Mild Steel.
- **Style:** Dome and Acorn Post Cap.
- **Post size:** 1-3/8", 1-5/8", 2", 2-1/2", 3", 4", 6-5/8".



## VIFF - 08 : POST CAP DOME

Standard Finish : Pre Galvanised | Hot Dipped Galvanised

- **Material:** Pressed Mild Steel.
- **Style:** Dome and Acorn Post Cap.
- **Post size:** 1-3/8", 1-5/8", 2", 2-1/2", 3", 4", 6-5/8".



# CHAIN LINK FENCE ACCESSORIES

## VIFF - 09 : LINE POST CAP

Standard Finish : Pre Galvanised | Hot Dipped Galvanised

- **Material:** Pressed Mild Steel.
- **Size:** 1-5/8" × 1-3/8", 2" × 1-3/8", 1-5/8" × 1-5/8", 2" × 1-5/8", 2-1/2" × 1-5/8", 3" × 1-5/8", 3-1/2" × 1-5/8", 4" × 1-5/8".



## VIFF - 10 : TENSION BAR

Standard Finish : Pre Galvanised | Hot Dipped Galvanised

- **Material:** Mild Steel..
- **Width:** 5/8", 3/4", 3/8".
- **Thickness:** 3/16", 1/4".
- **Height:** 36", 42", 48", 60", 72", 84", 96", 108", 120", 144".



## VIFF - 11 : CARRIAGE BOLT

Standard Finish : Galvanised | Hot Dipped Galvanised

- **Material:** Mild Steel..
- **Diameter:** 5/16 & 3/8 inch.
- **Length:** 1-1/4, 1-1/2, 2, 2-1/4, 2-1/2, 3 & 3-1/2 inch.
- Nut is included



## VIFF - 12 : BOULEVARD CLAMP FULL

Standard Finish : Pre Galvanised | Hot Dipped Galvanised

- **Material:** Pressed Mild Steel.

POST	RAIL
1-3/8"	1-3/8"
1-5/8"	1-3/8"
2"	1-3/8"



- **Bolt Size:** 5/16"x2" , 3/8"x2-1/2"

## VIFF - 13 : BOULEVARD CLAMP HALF

Standard Finish : Zinc Coating | Hot Dipped Galvanised

- **Material:** Pressed Mild Steel.

POST	RAIL
1-3/8"	1-3/8"
1-5/8"	1-5/8"
2"	2"
2-1/2"	1-3/8", 1-5/8", 2"
3"	1-3/8", 1-5/8", 2"
4"	1-3/8", 1-5/8", 2"



- **Bolt Size:** 5/16"x2" , 3/8"x2-1/2"

## VIFF - 14 : FRAME / POST HINGE MALE

Standard Finish : Galvanised | Hot Dipped Galvanised

- **Material:** Pressed Mild Steel.
- **Size:** 1-3/8", 1-5/8", 2" (1-7/8")  
2-1/2" (2-3/8"), 3" (2-7/8")
- **Pin Size:** 5/8"
- **Bolt Size:** 5/16"x2" , 3/8"x2-1/2"



## VIFF - 15 : FRAME / POST HINGE FEMALE

Standard Finish : Galvanised | Hot Dipped Galvanised

- **Material:** Pressed Mild Steel.
- **Size:** 1-3/8", 1-5/8", 2"
- **Pin Size:** 5/8"
- **Bolt Size:** 3/8"x2" , 3/8"x2-1/2"



## VIFF - 16 : TENSION WIRE CLIP

Standard Finish : Pre Galvanised | Hot Dipped Galvanised

- **Material:** Mild Steel..
- **Wire gauge:** 9 gauge, 11 gauge, 14 gauge.
- **Size:** 3/4", 1/2", 3/8".



## CHAIN LINK FENCE ACCESSORIES

### VIFF - 17 : GATE CLIP

Standard Finish : Pre Galvanised | Hot Dipped Galvanised

- Material: Pressed Mild Steel
- Post size: 1-3/8".
- Thickness: 14 gauge



### VIFF - 18 : TOP RAIL SLEEVE

Standard Finish : Pre Galvanised | Hot Dipped Galvanised

- Material: M.S Pipe
- Outside diameter: 1-3/8, 1-5/8 and 2 in.
- Wall thickness: 17 gauge.
- Length: 6" & 7".



### VIFF - 19 : CHAIN LINK MOUNT HINGE

Standard Finish : Galvanised | Hot Dipped Galvanised

- Material: Pressed Mild Steel.
- Plate: 1-1/2" x 4" and 2-3/4" x 5".
- Pin diameter: 5/8".



### VIFF - 20 : END RAIL CLAMPS

Standard Finish : Pre Galvanised | Hot Dipped Galvanised

- Material: Pressed Mild Steel.
- Size: 1-3/8" x 1-3/8" and 2-3/8" x 1-5/8"



### VIFF - 21 : LAG SCREW HINGE

Standard Finish : Galvanised | Hot Dipped Galvanised

- Material: Mild Steel..
- Pin diameter: 5/8". • Length: 4-1/2" and 6".



### VIFF - 22 : J-BOLT HINGE

Standard Finish : Zinc | Hot Dipped Galvanised

- Material: Mild Steel..
- Pin diameter: 5/8".
- Size: 5/8" x 4-1/2", 5/8" x 10", 5/8" x 12".



### VIFF - 23 : BRACKET WINDER SHORT

Standard Finish : Pre Galvanised | Hot Dipped Galvanised

- Material: Pressed Mild Steel.
- Size: 4"



### VIFF - 24 : EYE BOLT WITH ADOPTER

Standard Finish : Pre Galvanised | Hot Dipped Galvanised

- Material: Mild Steel..
- Size: 4", 6"





## CHAIN LINK FENCE ACCESSORIES

### VIFF - 25 : RATCHET WINDER

Standard Finish : Pre Galvanised | Hot Dipped Galvanised



- **Material:** Pressed Mild Steel.
- **Size:** Length 3"x5"

### VIFF - 26 : RATCHET WINDER WITH EYE BOLT

Standard Finish : Pre Galvanised | Hot Dipped Galvanised



- **Material:** Pressed Mild Steel.
- **Size:** Length 3"x5" (Bolt 6")

### VIFF - 27 : BULL DOG HINGE

Standard Finish : Pre Galvanised | Hot Dipped Galvanised



- **Material:** Pressed Mild Steel.
- **Size:** 2-1/2" (2-3/8"), 3" (2-7/8")  
3-1/2" (3-3/8"), 4" (3-7/8")  
4-1/2" (4-3/8"), 6-5/8"

### VIFF - 28 : GATE CORNER L-SHAPE

Standard Finish : Pre Galvanised | Hot Dipped Galvanised



- **Material:** Pressed Mild Steel.
- **Gauge:** 12 gauge, 14 gauge.
- **Matched pipe size:** 1-3/8", 2"
- **Accessories:** self-screw.

### VIFF - 29 : CROSS CONNECTOR

Standard Finish : Zinc Coating | Hot Dipped Galvanised



- **Material:** Pressed Mild Steel.
- **Size:** 1-3/8" x 1-3/8"  
1-3/8" x 1-5/8"  
1-5/8" x 1-5/8"  
2" x 1-5/8"

### VIFF - 30 : TRUSS ROD TIGHTENER

Standard Finish : Pre Galvanised | Hot Dipped Galvanised



- **Material:** Pressed Mild Steel.
- **Size:** 1/4" x 1"
- **Length:** 4-3/4"

### VIFF - 31 : HEAVY HINGES

Standard Finish : Pre Galvanised | Hot Dipped Galvanised



- **Material:** Mild Steel.
- **Size:** 3/4"x2"

### VIFF - 32 : SADDLE CLAMP

Standard Finish : Pre Galvanised | Hot Dipped Galvanised



- **Material:** Pressed Mild Steel.
- **Size:** 1-3/8" x 1-3/8"  
1-5/8" x 1-5/8"  
2(1-7/8")x2(1-7/8")

# KEI KLAMP PIPE FITTING

## SOCKET SHORT TEE KLAMP-101



Prod. No.	101-VI-A	101-VI-B	101-VI-C	101-VI-D	101-VI-E
SIZE (Inchs)	3/4	1	1 1/4	1 1/2	2
Pipe O.D. (M.M)	26.90	33.70	42.40	48.30	60.30
DIM-A	61.00	69.00	88.00	99.00	121.00
DIM-B	38.00	49.00	58.00	64.50	75.00
DIM-C	28.00	35.00	44.00	50.00	62.00
DIM-D	43.00	52.00	59.00	67.00	79.00
Wt. Kgs.	0.255	0.310	0.465	0.580	1.070

## SOCKET LONG TEE KLAMP - 104



Prod. No.	104-VI-A	104-VI-B	104-VI-C	104-VI-D	104-VI-E
SIZE (Inchs)	3/4	1	1 1/4	1 1/2	2
Pipe O.D. (M.M)	26.90	33.70	42.40	48.30	60.30
DIM-A	59.00	70.00	88.00	98.00	121.00
DIM-B	83.00	93.00	120.00	136.00	168.00
DIM-C	28.00	35.00	44.00	50.00	62.00
DIM-D	36.00	46.00	55.00	61.00	75.00
Wt. Kgs.	0.410	0.430	0.775	0.960	1.920

## THREE WAY BLEND CORNER-116



Prod. No.	116-VI-A	116-VI-B	116-VI-C	116-VI-D	116-VI-E
SIZE (Inchs)	3/4	1	1 1/4	1 1/2	2
Pipe O.D. (M.M)	26.90	33.70	42.40	48.30	60.30
DIM-A	60.00	70.00	91.00	99.00	123.00
DIM-B	60.00	70.00	91.00	99.00	122.00
DIM-C	28.00	35.00	44.00	50.00	62.00
DIM-D	37.00	46.00	57.00	63.00	75.00
Wt. Kgs.	0.420	0.500	0.880	1.135	2.005

## THREE SOCKET LONG TEE KLAMP-119



Prod. No.	119-VI-A	119-VI-B	119-VI-C	119-VI-D	119-VI-E
SIZE (Inchs)	3/4	1	1 1/4	1 1/2	2
Pipe O.D. (M.M)	26.90	33.70	42.40	48.30	60.30
DIM-A	82.00	92.00	119.00	134.00	173.00
DIM-B	42.00	46.00	56.00	62.00	74.00
DIM-C	28.00	35.00	44.00	50.00	62.00
DIM-D	42.00	51.00	61.00	67.00	78.00
Wt. Kgs.	0.300	0.410	0.630	0.780	1.610

## KEI KLAMP PIPE FITTING

### TWO WAY ELBOW 90° PIPE KLAMP-125



Prod. No.	125-VI-A	125-VI-B	125-VI-C	125-VI-D	125-VI-E
SIZE (Inchs)	3/4	1	1 1/4	1 1/2	2
Pipe O.D. (M.M)	26.90	33.70	42.40	48.30	60.30
DIM-A	60.00	69.00	87.00	99.00	120.00
DIM-B	60.00	69.00	87.00	99.00	120.00
DIM-C	28.00	35.00	44.00	50.00	62.00
DIM-D	38.00	47.00	56.00	62.00	75.00
Wt. Kgs.	0.300	0.340	0.560	0.800	1.410

### THREE WAY OPEN CORNER - 128



Prod. No.	128-VI-A	128-VI-B	128-VI-C	128-VI-D	128-VI-E
SIZE (Inchs)	3/4	1	1 1/4	1 1/2	2
Pipe O.D. (M.M)	26.90	33.70	42.40	48.30	60.30
DIM-A	60.00	69.00	88.00	100.00	124.00
DIM-B	60.00	69.00	88.00	100.00	123.00
DIM-C	28.00	35.00	44.00	59.00	62.00
DIM-D	38.00	46.00	56.00	62.00	75.00
Wt. Kgs.	0.310	0.400	0.750	0.900	1.500

### BASE FLANGE - 131



Prod. No.	131-VI-A	131-VI-B	131-VI-C	131-VI-D	131-VI-E
SIZE (Inchs)	3/4	1	1 1/4	1 1/2	2
Pipe O.D. (M.M)	26.90	33.70	42.40	48.30	60.30
DIM-A	40.00	50.00	51.00	59.00	65.00
DIM-B	79.00	93.00	104.00	114.00	129.00
DIM-C	28.00	35.00	44.00	50.00	62.00
DIM-D	37.00	48.00	55.00	60.00	76.00
Wt. Kgs.	0.445	0.560	0.585	0.870	1.190

### RAILING BASE FLANGE-132



Prod. No.	132-VI-A	132-VI-B	132-VI-C	132-VI-D	132-VI-E
SIZE (Inchs)	3/4	1	1 1/4	1 1/2	2
Pipe O.D. (M.M)	26.90	33.70	42.40	48.30	60.30
DIM-A	77.00	91.00	92.00	93.00	127.00
DIM-B	118.00	128.00	140.00	157.00	164.00
DIM-C	28.00	35.00	44.00	50.00	62.00
DIM-D	38.00	46.00	55.00	62.00	75.00
Wt. Kgs.	0.730	0.890	1.110	1.380	1.940

## KEI KLAMP PIPE FITTING

### PLASTIC PLUG - 133



Prod. No.	133-VI-A	133-VI-B	133-VI-C	133-VI-D	133-VI-E
SIZE (Inchs)	3/4	1	1 1/4	1 1/2	2
Pipe O.D. (M.M)	26.90	33.70	42.40	48.30	60.30
BIM-B	29.00	30.50	33.00	34.00	36.00
DIM-C	22.5-28	28-35	36-44	39-50	54-62
BIM-D	27.00	32.50	40.50	47.00	59.50
Wt. Kgs.	0.008	0.010	0.015	0.020	0.025

### RAIL SUPPORT-143



Prod. No.	143-VI-A	143-VI-B	143-VI-C	143-VI-D	143-VI-E
SIZE (Inchs)	3/4	1	1 1/4	1 1/2	2
Pipe O.D. (M.M)	26.90	33.70	42.40	48.30	60.30
DIM-A	70.00	80.00	92.00	102.00	116.00
DIM-B	37 & 77.00	41 & 89.00	47 & 102.00	53 & 110.00	62 & 116.00
DIM-C	28.00	35.00	44.00	50.00	62.00
DIM-D	36.00	39.00	46.00	58.00	70.00
Wt. Kgs.	0.366	0.450	0.665	0.797	1.051

### IN LINE EXTERNAL TUBE CONNECTOR-149



Prod. No.	149-VI-A	149-VI-B	149-VI-C	149-VI-D	149-VI-E
SIZE (Inchs)	3/4	1	1 1/4	1 1/2	2
Pipe O.D. (M.M)	26.90	33.70	42.40	48.30	60.30
DIM-A	76.00	91.00	100.00	100.00	124.00
DIM-B	38.00	46.00	55.00	62.00	78.00
DIM-C	28.00	35.00	44.00	50.00	62.00
DIM-D	43.00	50.00	62.00	67.00	79.00
Wt. Kgs.	0.300	0.370	0.520	0.620	1.190

### SHORT SWIVEL TEE PAIR-148



Prod. No.	148-VI-A	148-VI-B	148-VI-C	148-VI-D	148-VI-E
SIZE (Inchs)	3/4	1	1 1/4	1 1/2	2
Pipe O.D. (M.M)	26.90	33.70	42.40	48.30	60.30
DIM-A	79.00	84.00	103.00	120.00	153.00
DIM-B	44.00	53.00	61.00	68.00	79.00
DIM-C	28.00	35.00	44.00	50.00	62.00
DIM-D	38.00	48.00	57.00	61.00	74.00
Wt. Kgs.	0.230	0.320	0.390	0.715	1.140

## KEI KLAMP PIPE FITTING

### FOUR SOCKET CROSS-158

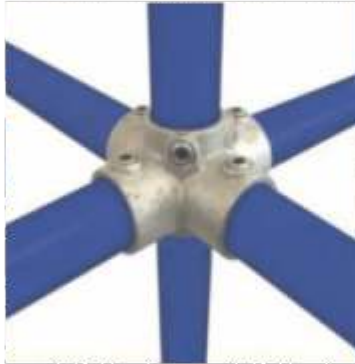

Prod. No.	158-VI-A	158-VI-B	158-VI-C	158-VI-D	158-VI-E
SIZE (Inchs)	3/4	1	1 1/4	1 1/2	2
Pipe O.D. (M.M)	26.90	33.70	42.40	48.30	60.30
DIM-A	82.00	94.00	120.00	135.00	168.00
DIM-B	82.00	94.00	120.00	135.00	168.00
DIM-C	28.00	35.00	44.00	50.00	62.00
DIM-D	38.00	46.00	56.00	59.00	75.00
Wt. Kgs.	0.519	0.612	1.875	1.492	2.350

### KLAMPING CROSSOVER-160



Prod. No.	160-VI-A	160-VI-B	160-VI-C	160-VI-D	160-VI-E
SIZE (Inchs)	3/4	1	1 1/4	1 1/2	2
Pipe O.D. (M.M)	26.90	33.70	42.40	48.30	60.30
DIM-A	74.00	92.00	107.00	123.00	144.00
DIM-B	42.00	54.00	62.00	67.00	80.00
DIM-C	28.00	35.00	44.00	50.00	62.00
DIM-D	21 & 41.00	33 & 53.00	48 & 61.00	70 & 51.00	68 & 80.00
Wt. Kgs.	0.266	0.350	0.470	0.710	0.990

### OFFSET 90' CROSSOVER-161



Prod. No.	161-VI-A	161-VI-B	161-VI-C	161-VI-D	161-VI-E
SIZE (Inchs)	3/4	1	1 1/4	1 1/2	2
Pipe O.D. (M.M)	26.90	33.70	42.40	48.30	60.30
DIM-A	72.00	85.00	104.00	119.00	140.00
DIM-B	37.00	47.00	55.00	64.00	74.00
DIM-C	28.00	35.00	44.00	50.00	62.00
DIM-D	32.00	40.00	45.00	51.00	62.00
Wt. Kgs.	0.209	0.352	0.547	0.603	1.003

### COMBINATION SOCKET TEE AND CROSSOVER - 165



Prod. No.	165-VI-A	165-VI-B	165-VI-C	165-VI-D	165-VI-E
SIZE (Inchs)	3/4	1	1 1/4	1 1/2	2
Pipe O.D. (M.M)	26.90	33.70	42.40	48.30	60.30
DIM-A	96.00	110.00	139.00	152.00	192.00
DIM-B	43.00	51.00	61.00	65.00	80.00
DIM-C	28.00	35.00	44.00	50.00	62.00
DIM-D	38.00	46.00	56.00	61.00	75.00
Wt. Kgs.	0.306	0.527	0.705	0.932	1.576

# KEI KLAMP PIPE FITTING

## DOUBLE SWIVEL SOCKET-167



Prod. No.	167-VI-A	167-VI-B	167-VI-C	167-VI-D	167-VI-E
SIZE (Inchs)	3/4	1	1 1/4	1 1/2	2
Pipe O.D. (M.M)	26.90	33.70	42.40	48.30	60.30
BIM-A	205.00	209.00	233.00	260.08	293.00
DIM-B	37.00	45.00	56.00	62.00	74.00
BIM-C	28.00	35.00	44.00	50.00	62.00
DIM-D	38.00	45.00	56.00	61.00	74.00
Wt. Kgs.	1.010	1.136	1.391	1.604	2.104

## CORNER SWIVEL SOCKET - 168



Prod. No.	168-VI-A	168-VI-B	168-VI-C	168-VI-D	168-VI-E
SIZE (Inchs)	3/4	1	1 1/4	1 1/2	2
Pipe O.D. (M.M)	26.90	33.70	42.40	48.30	60.30
BIM-A	129.00	133.00	144.00	159.08	182.00
DIM-B	38.00	45.00	56.00	63.00	73.00
BIM-C	28.00	35.00	44.00	50.00	62.00
DIM-D	38.00	46.00	55.00	62.00	74.00
Wt. Kgs.	0.992	1.145	1.416	1.585	2.081

## SINGLE SWIVEL FLANGE KIT-169



Prod. No.	169-VI-A	169-VI-B	169-VI-C	169-VI-D	169-VI-E
SIZE (Inchs)	3/4	1	1 1/4	1 1/2	2
Pipe O.D. (M.M)	26.90	33.70	42.40	48.30	60.30
BIM-A	122.00	130.00	149.00	164.00	181.00
DIM-B	39.00	46.00	56.00	63.50	74.00
BIM-C	28.00	35.00	44.00	50.00	62.00
DIM-D	43.00	51.00	62.00	66.00	80.00
Wt. Kgs.	0.615	0.625	0.830	1.020	1.345

## MALE SWIVEL-173 M



Prod. No.	173M-VI-A	173M-VI-B	173M-VI-C	173M-VI-D	173M-VI-E
SIZE (Inchs)	3/4	1	1-1/4	1-1/2	2
Pipe O.D. (M.M)	26.90	33.70	42.40	48.30	60.30
BIM-A	19.00	133.00	144.00	159.08	182.00
DIM-B	60.00	45.00	56.00	63.00	73.00
BIM-C	29.00	36.00	45.00	51.00	63.00
DIM-D	38.00	46.00	55.00	62.00	74.00
Hole Size	10.50	10.50	10.50	10.50	10.50
Wt. Kgs.	0.220	0.260	0.370	0.560	0.720

## KEI KLAMP PIPE FITTING

### MALE SWIVEL-173F



Prod. No.	173F-VI-A	173F-VI-B	173F-VI-C	173F-VI-D	173F-VI-E
SIZE (Inchs)	3/4	1	1-1/4	1-1/2	2
Pipe O.D. (M.M)	26.90	33.70	42.40	48.30	60.30
DIM-A	19.00	19.00	19.00	19.00	24.00
DIM-B	60.00	62.00	72.00	80.00	96.00
DIM-C	29.00	27.00	34.00	35.00	42.00
DIM-D	38.00	45.00	55.00	61.00	73.00
Hole Size	10.50	10.50	10.50	10.50	10.50
Wt. Kgs.	0.270	0.340	0.440	0.460	0.800

### SIDE OUTLET TEE - 176



Prod. No.	176-VI-A	176-VI-B	176-VI-C	176-VI-D	176-VI-E
SIZE (Inchs)	3/4	1	1 1/4	1 1/2	2
Pipe O.D. (M.M)	26.90	33.70	42.40	48.30	60.30
DIM-A	61.00	69.00	89.00	100.00	123.00
DIM-B	83.00	92.00	120.00	136.50	171.00
DIM-C	28.00	35.00	44.00	50.00	62.00
DIM-D	38.00	47.00	56.00	61.00	74.00
Wt. Kgs.	0.357	0.531	0.788	1.214	1.873

### GURB SCREWS-198



Prod. No.	198-VI-A	198-VI-B	198-VI-C	198-VI-D	198-VI-E
SIZE (Inchs)	3/4	1	1 1/4	1 1/2	2
DIM-A	1/4"	1/4"	5/16"	5/16"	5/16"
DIM-B	1/4"	1/4"	3/8"	3/8"	3/8"
Wt. Kgs.	0.008	0.008	0.012	0.012	0.012



## OUR PRODUCT RANGE :



**WROUGHT IRON HARDWARE PRODUCTS**  
[www.vikasindustries.co](http://www.vikasindustries.co)

**SCAFFOLDING & ACCESSORIES**  
[www.vikasindustries.net](http://www.vikasindustries.net)



**FORGED FITTINGS**  
[www.vikasindustries.net](http://www.vikasindustries.net)

**PIPE HANGERS / CLAMPS**  
[www.vikasindustries.net](http://www.vikasindustries.net)



# VIKAS INDUSTRIES

**A GOVT. OF INDIA RECOGNISED STAR EXPORT HOUSE**

**AN ISO 9001: 2015 CERTIFIED COMPANY**

AN UL LISTED COMPANY

F-76-77, Phase-VII, Focal Point, Ludhiana-141010 (Pb.) INDIA

Works : Focal Point Extn., Dhandari Khurd, Ludhiana.

Mobile: +91-98140-03794, +91-98554-29173, +91-98554-29174

E-mail: [export@vikasindustriesindia.com](mailto:export@vikasindustriesindia.com), [info@vikasindustriesindia.com](mailto:info@vikasindustriesindia.com)

[vikas@vikasindustries.co](http://vikas@vikasindustries.co) | [www.vikasindustries.net](http://www.vikasindustries.net)