



VIKAS INDUSTRIES

A GOVT. OF INDIA RECOGNISED STAR EXPORT HOUSE



AN ISO 9001: 2015 CERTIFIED COMPANY

A UL LISTED COMPANY

CAP

ASME B16.11-2016 (Revision of ASME B16.11-2011)

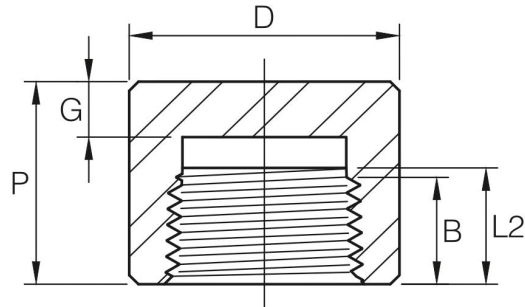
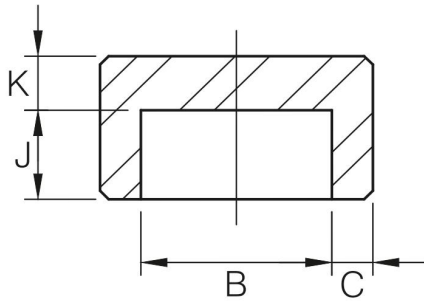

Dimensions are in millimeters.

Dimensions are in millimeters.

DN	Nom. Pipe Size	B ⁽²⁾	C ⁽¹⁾		K (Min)	J (Min)
			(Avg)	(Min)		

3000Lb

6	1/8	10.8	3.18	3.18	4.8	9.5
8	1/4	14.2	3.78	3.30	4.8	9.5
10	3/8	17.6	4.01	3.50	4.8	9.5
15	1/2	21.8	4.67	4.09	6.4	9.5
20	3/4	27.2	4.90	4.27	6.4	12.5
25	1	33.9	5.69	4.98	9.6	12.5
32	1-1/4	42.7	6.07	5.28	9.6	12.5
40	1-1/2	48.8	6.35	5.54	11.2	12.5
50	2	61.2	6.93	6.04	12.7	16.0
65	2-1/2	73.9	8.76	7.67	15.7	16.0
80	3	89.8	9.52	8.30	19.0	16.0
100	4	115.2	10.69	9.35	22.4	19.0

6000Lb

6	1/8	10.8	3.96	3.43	6.4	9.5
8	1/4	14.2	4.60	4.01	6.4	9.5
10	3/8	17.6	5.03	4.37	6.4	9.5
15	1/2	21.8	5.97	5.18	7.9	9.5
20	3/4	27.2	6.96	6.04	7.9	12.5
25	1	33.9	7.92	6.93	11.2	12.5
32	1-1/4	42.7	7.92	6.93	11.2	12.5
40	1-1/2	48.8	8.92	7.80	12.7	12.5
50	2	61.2	10.92	9.50	15.7	16.0

9000Lb

15	1/2	21.8	9.35	8.18	11.2	9.5
20	3/4	27.2	9.78	8.56	12.7	12.5
25	1	33.9	11.38	9.96	14.2	12.5
32	1-1/4	42.7	12.14	10.62	14.2	12.5
40	1-1/2	48.8	12.70	11.12	15.7	12.5
50	2	61.2	13.84	12.12	19.0	16.0

(1) Average of socket wall thickness around periphery shall be no less than listed values. The minimum values are permitted in localized areas.

(2) Tolerance see page 14

DN	Nom. Pipe Size	Length of Thread (Min)		P	D	G (Min)
		B ^(*)	L2 ^(*)			

3000Lb

6	1/8	6.4	6.7	19	16	4.8
8	1/4	8.1	10.2	25	19	4.8
10	3/8	9.1	10.4	25	22	4.8
15	1/2	10.9	13.6	32	28	6.4
20	3/4	12.7	13.9	37	35	6.4
25	1	14.7	17.3	41	44	9.7
32	1-1/4	17.0	18.0	44	57	9.7
40	1-1/2	17.8	18.4	44	64	11.2
50	2	19.0	19.2	48	76	12.7
65	2-1/2	23.6	28.9	60	92	15.7
80	3	25.9	30.5	65	108	19.0
100	4	27.7	33.0	68	140	22.4

6000Lb

6	1/8	6.4	6.7	22	22	6.4
8	1/4	8.1	10.2	27	25	6.4
10	3/8	9.1	10.4	27	32	6.4
15	1/2	10.9	13.6	33	38	7.9
20	3/4	12.7	13.9	38	44	7.9
25	1	14.7	17.3	43	57	11.2
32	1-1/4	17.0	18.0	46	64	11.2
40	1-1/2	17.8	18.4	48	76	12.7
50	2	19.0	19.2	51	92	15.7
65	2-1/2	23.6	28.9	64	108	19.0
80	3	25.9	30.5	68	127	22.4
100	4	27.7	33.0	75	159	28.4

(*) Dimension B is minimum length of perfect thread. The length of useful thread (B plus threads with fully formed roots and flat crests) shall not be less than L2 (effective length of external thread) required by American National Standard for pipe threads (ANSI / ASME B1.20.1)